

## OSCILLATORS

Basically, an oscillator is an amplifier whose output is connected back to its own input.

However, for oscillation to occur certain conditions must be met:

- 1) The transistor must have enough gain (amplification) to overcome feedback losses
- 2) The feedback must be in the *correct phase*. It must be *positive* feedback.

There are various ways to obtain the correct feedback to ensure oscillation.

- (a) Mutual inductance (transformer action) between the coils in the input and output circuits.
- (b) Feedback circuit from output to input.
- (c) Tapped coil. Part of the coil is in the input circuit and part of the coil is in the output circuit.

This circuit (A) shows the collector connected to a tap on the tuned circuit coil. This enables the low impedance transistor to be matched to the high impedance of the parallel tuned circuit at resonance.

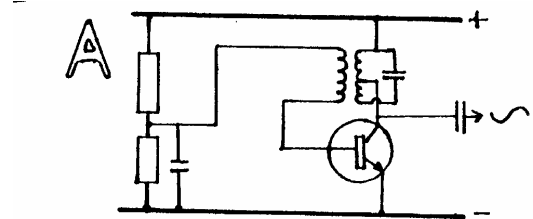

(B) It is important that the crystal oscillator is not 'run' too hard or the crystal may fracture due to the violent agitation.

(C) This oscillator uses the *tapped coil* technique.

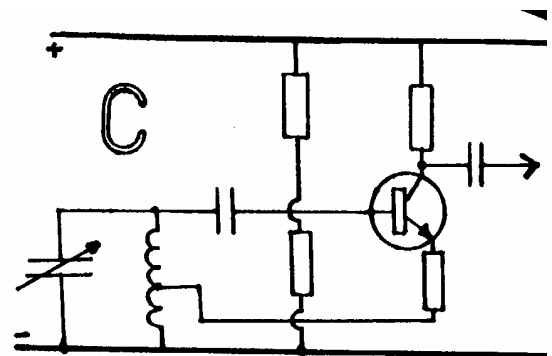
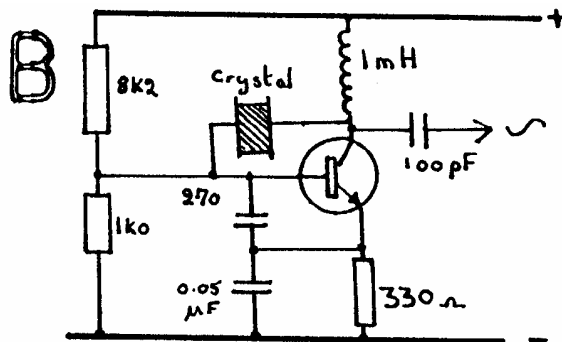

## CRYSTAL OSCILLATORS

A property of certain crystalline substances is that, when stressed, they actually produce very small voltages and, conversely, if radio frequency voltages are applied to the crystal it will vibrate.

This is known as the piezo-electric effect. If the applied radio frequency is varied, there will be one frequency at which the crystal will vibrate at a much greater amplitude than at other frequencies. This is the resonant frequency of the crystal. This frequency depends upon the thickness of the slice of crystal.

Thin slices of quartz are used in oscillators to determine their frequency of oscillation. The crystal behaves as if it were a tuned circuit with a very high 'Q'. The 'Q' may be as high as 2000. The slice of crystal is mounted between two small connecting plates and fitted into a metal container or, for greater precision, in an evacuated glass envelope.

## TRANSMITTERS

An oscillator is the basis of any radio transmitter. Connecting an aerial directly to an oscillator could make a very simple, but not very practical transmitter. The frequency of transmission would be at the oscillator frequency and would be of very low power. Also it would not be transmitting any information - just a constant signal or 'carrier'.

As there is a direct connection from the oscillator, any movements of the aerial (or anything near to the aerial) would vary its capacitance to earth, and this would change the oscillator frequency.

To ensure that the frequency of the oscillator is not affected by such changes it is usual to feed its output into a buffer amplifier. A buffer stage may have gain (amplification), loss or unity gain. Amplification is purely a possible by-product, its main function is isolation. The buffer ensures that the oscillator output always "looks" into the same load impedance. An impedance that is independent of any variations in the rest of the transmitter.

In a simple transmitter the oscillator will be crystal controlled to ensure adequate frequency stability. If it is required to have a transmitter capable of operating at any part of the amateur bands it will be necessary to replace the crystal oscillator with a Variable Frequency Oscillator (VFO). It is possible to use one VFO in conjunction with a multiplier stage to give operation on several Amateur Bands.

The power from a multiplier stage will not be very great so further amplification is necessary. The multiplier stage is therefore followed by a power amplifier (PA) stage. The PA output is then connected to the aerial via a low-pass filter.

(Why the filter?...think about it. More later,.....)

The transmitter now comprises: -

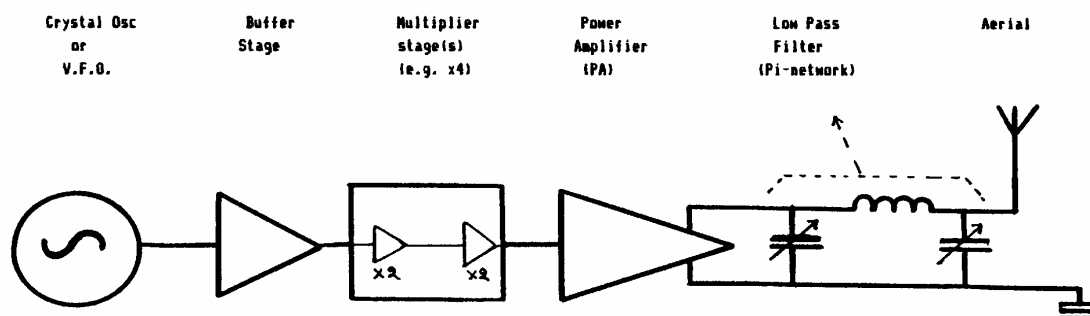

This transmitter can be made to operate on various Amateur Bands by switching inside the multiplier stage.

The latest HF bands to be given to the Amateur Service (10.1-1015; 18.068 -18.168 & 24.89 -24.99 MHz) are not harmonically related to each other or other amateur bands so different techniques have to be used. This will be dealt with in a later lesson.

## Transmitter (continued)

The switching in the multiplier stage varies the tuned circuits so that either the basic frequency (fundamental) or one of the harmonics is selected. Although, in general, amateur bands are harmonically related they do vary in bandwidth and so the whole 'swing' of the VFO is not used.

VFO range	Multiplication	Band	Transmitted Frequencies
1.61-2.0 MHz	times 1	160 Metre	1.61-2.0 MHz
1.75-1.9 MHz	times 2	80 Metres	3.5-3.8 MHz
1.79-1.775MHz	times 4	40 Metres	7.0-2.1 MHz
1.75-1.793MHz	times 8	20 Metres	14.0-14.35 MHz
1.75-1.787MHz	times 12	15 Metres	21.0-21.45 MHz

If a multiplication of more than four times is required it is usual to use two or more multiplier stages.

For example 'eight times' could be done by :-

Either: 2 x 4 (Two multiplier stages) or 2 x 2 x 2 ( Three multiplier stages).

We will now look in more detail at the basic stages of a transmitter.

### THE VARIABLE FREQUENCY OSCILLATOR

To permit operation on any frequency within the amateur bands (without a huge selection of crystals) it is necessary to use an oscillator that can be continuously tuned.

It is the inductor and capacitor of the tuned circuit that determines the frequency of oscillation.

Remember, resonant frequency =  $1 / 2\pi \sqrt{LC}$ , Thus to change the frequency of resonance (hence, oscillator frequency) it is necessary to be able to vary either the value of the inductance or the value of the capacitance. The most common method is to use a variable capacitor. It is most important that, once the oscillator has been set to the required frequency, it stays there does not drift in frequency.

*The oscillator must be stable.*

Stability is even more important if frequency multiplication is to be employed.

Imagine a transmitter, operating on 28.6 MHz, using a basic VFO on 1.6 MHz.

*Any VFO drift will have been magnified 16 times by the time it is transmitted.*

#### To ensure good frequency stability:

- 1) Use good quality components -particularly the coil and the tuning capacitor.
- 2) All wiring should use short thick conductors that are fixed so they cannot vibrate,
- 3) Mount the tuned circuit (L&C) away from any sources of heat. Temperature changes would cause the components to expand or contract thus varying their value and their combined resonant frequency.
- 4) Use stabilised supply voltages.
- 5) Ensure that the 'loading' on the VFO does not vary. The oscillator should always be followed by a buffer stage.
- 6) Do not 'key' the VFO as this would result in Morse with severe 'chirp'.
- 7) Allow a few minutes for the VFO to settle down before commencing transmission.

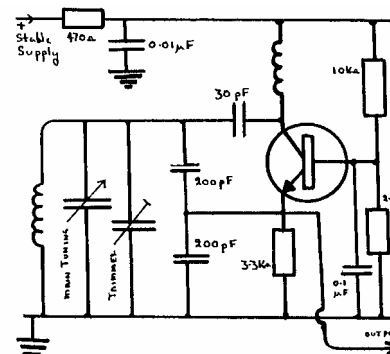

## BUFFER STAGES

The object of the buffer stage is to provide the VFO with a constant load.

It will often have a high input impedance (to minimise the load on the VFO) and a low output impedance to feed the following stages. Thus a buffer acts as an *isolating impedance transformer*. Buffers may be *tuned* or *untuned*.

The buffer is a suitable stage to "key" the transmitter for CW (Morse) transmissions. Keying is best done at a point in the transmitter where the signal is low power, but should never be done at the VFO. In the "key up" position the buffer is turned off and no signal is transmitted. In the "key down" position the buffer is turned on and the oscillations are passed forward to be transmitted.

However, if the Morse key is connected directly to A/B (as shown dotted) the transmitted waveform would have an abrupt start & finish to each Morse element (Fig 2). These sudden transitions would cause the transmitted signal to be rich in harmonics.

These would appear as key-clicks, both in and out of amateur bands and must be prevented.

Fig 1 should be used between the buffer (A/B) and the key and is known as a key-click filter. The components may be built into the transmitter or built into an external unit and connected in the lead from the key to the transmitter.

The filter will "round off" the waveform (fig 3).

If the values of the components in the filter are too high, the rounding will be exaggerated and the signal elements will run together (fig 4). Such a signal, while producing no harmonics, would produce unreadable Morse....

The components marked % affects the start of the waveform

The components marked x affect the end of the waveform

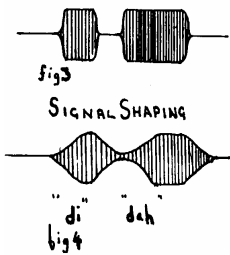
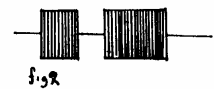
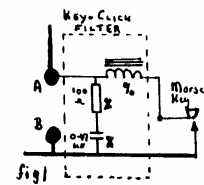
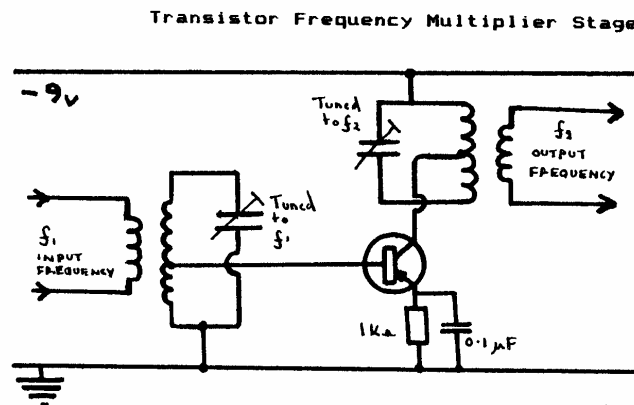

Fig 4

## FREQUENCY MULTIPLICATION

A pure sinewave contains only a single frequency. However if the waveform is distorted it will then contain many harmonic frequencies. Normally special care is taken to ensure such distortion and harmonics are avoided.

However, in a frequency multiplier, the input signal is distorted on purpose and the output circuit is tuned to the required harmonic.



Thus, when an amplifier is used as a multiplier it has to be designed to produce waveform distortion and hence, harmonics. This is usually achieved by biasing the transistor to the non-linear part of its operating characteristic. The transistor is usually operated in Class C for this purpose.

The tuned circuit at the input circuit is tuned to the input frequency and the tuned circuit at the output is tuned to select the required harmonic. Of course, harmonics only come in whole numbers so multiplier stage can only multiply in whole numbers. Also the higher the harmonic that is selected the lower will be its amplitude. In fact the third harmonic will have an amplitude one third of the fundamental etc. This is why it usual to use more than one multiplier stage where high multiplication factors are required.

So far we have covered the Oscillator (crystal or VFO), Buffer and Multiplier stages. When these are connected together they are known as the "exciter". A simple transmitter consists of an exciter plus a Power amplifier (PA). The PA is covered in a later lesson.

## TRANSMITTER DESIGN

The transmitter, using frequency multiplication, that has been described so far is only used in very simple (usually Morse) transmitters. This technique is usually employed in simple home constructed transmitters.

**Questions for Lesson 8**

Only short answers are required

- 8.1) How would you convert an audio amplifier into an oscillator?
- 8.2) What advantage is there in using a *crystal* in place of a normal tuned circuit?
- 8.3) Draw the circuit of a buffer stage and state the function of each component that you use.
- 8.4) What does "loading a VFO" mean?
- 8.5) Why are crystals sometimes mounted in "crystal ovens"?
- 8.6) You have constructed a multiplier stage. What determines its multiplication factor?
- 8.7) A transmitter has a VFO operating in the range 1.75-1.9 MHz and a multiplier stage to give an output in the Fifteen Metre Amateur Band.  
Unfortunately the VFO drifts up at a rate of 120 Hz per hour.  
Assuming that a transmission commences on 21.100 MHz what will the transmitted frequency be after three hours?
- 8.8) Why should you use thick wires in the construction of a "VFO" ?  
Why are thick wires less important in the case of a crystal controlled oscillator?
- 8.9) What are key clicks? Why are they undesirable? How can they be avoided ?
- 8.10) In a frequency multiplier, how would you prevent radio frequencies, that are present in the circuit but are not actually wanted in the final transmitted frequency?
- 8.11) During long transmissions how often should your callsign be transmitted?
- 8.12) If the call-sign is sent in Morse, what is the maximum speed that should be maximum used?
- 8.13) Apart from the call-sign, what is the maximum speed that should be used for the conversation part of a Morse transmission?
- 8.14) How long after the last log entry should the logbook be retained?
- 8.15) What is the function of a "Dummy load"?
- 8.16) Deleted
- 8.17) If you receive a report from a member of the public, that you are causing interference to their TV reception, what action should you take?
- 8.18) If there was a need for all Radio Amateurs to cease their operation, how would they be informed of that fact?